

Manual Version 01

Make sure you have all the latest information needed to use and enjoy this product!

Visit ternbicycles.com/support for updated:

 MANUALS
  COMPATIBILITY
  ARTICLES
  VIDEOS
  & MORE



What's Included

- Stem
- Handlebar and grips with integrated T-Tool

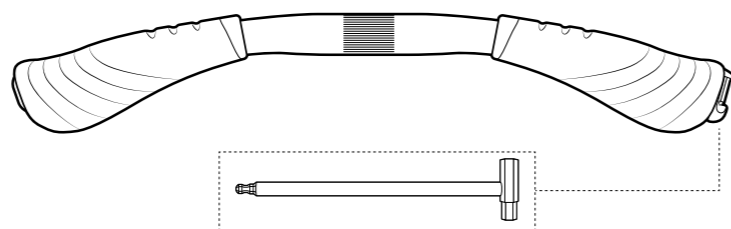
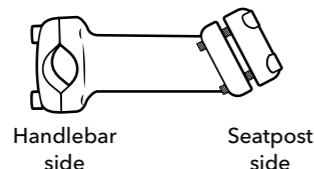

Installation

Tools required

- 5 mm Allen Wrench (part of the T-Tool)

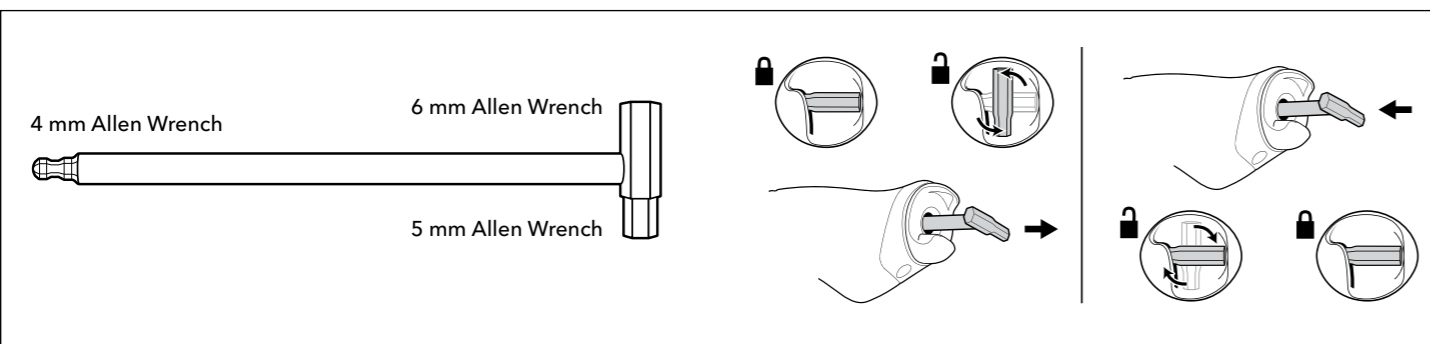

Mount Stem on Seatpost

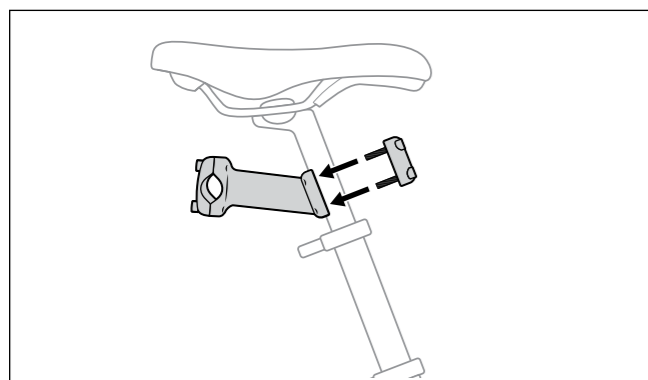

1. Remove Faceplate on Seatpost side.
2. Place Stem against the Seatpost (30.9 - 34.9 mm).
3. Verify Stem is aligned with the bike's rear rack.

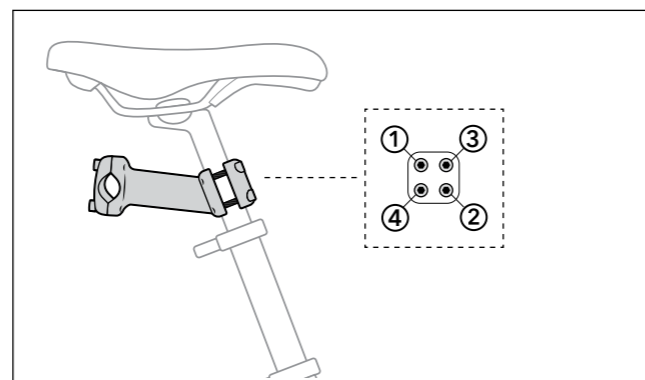

4. Place Faceplate onto Stem and tighten all bolts in cross pattern to a torque of 9-10 Nm.
5. Ensure gap between Stem and Faceplate remains even during tightening.

Installation (continued)

Mount Handlebar on Stem

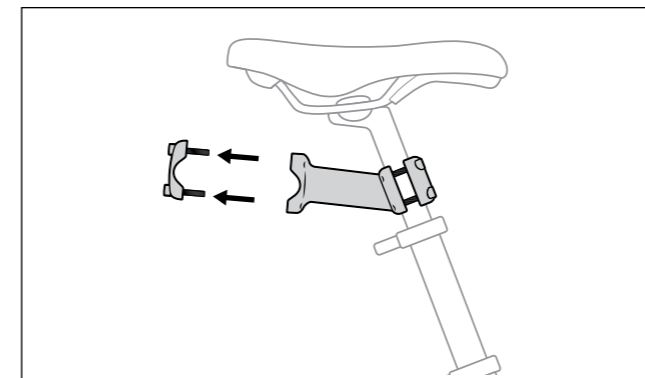

1. Remove Faceplate on Handlebar side.

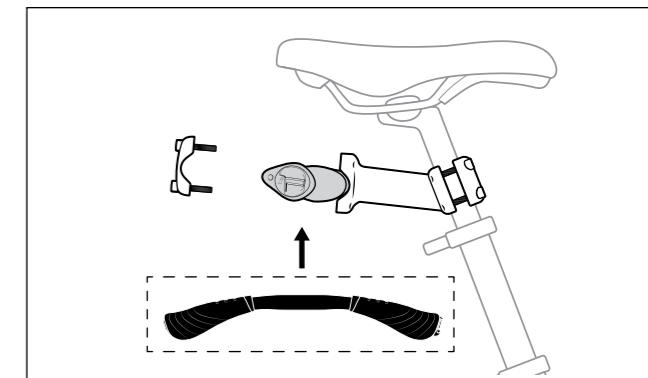

2. Place Handlebar in center.

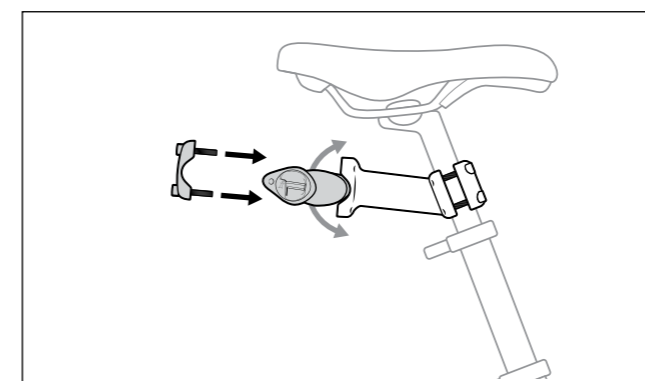

3. Place Faceplate on Stem and partially tighten all bolts.
4. Rotate Handlebar to find most comfortable grip angle for passenger.

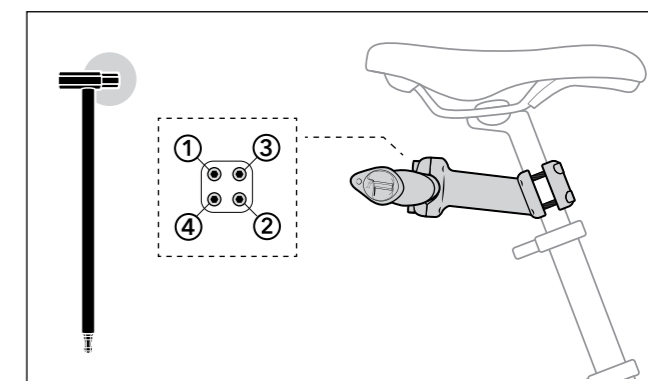

5. Tighten bolts in cross pattern to a torque of 9-10 Nm.
6. Ensure gap between Stem and Faceplate remains even during tightening.

LIMITED PRODUCT WARRANTY INFORMATION: This Product comes with a ONE (1) YEAR Limited Warranty from the date of retail purchase by the original end-user. If a material or workmanship defect arises and a valid claim is received within the Warranty Period, this Product will be replaced. Mobility Holdings cannot be held liable for damages to personal property due to misuse or improper care and maintenance. This Product Warranty does not, under any circumstance, cover the replacement or cost of any third party product used with or connected to the Product.

Tern, the Tern Werd (logotype), the Tern Berd (device), and Sidekick Flat Bars used alone or in combination are trade names, trade devices or registered trademarks of Mobility Holdings, Ltd.

© 2024. Tern is a trademark of Mobility Holdings, Ltd. All Rights Reserved.



 @ternbicycles

ternbicycles.com

Carrying Rear Passengers

Before carrying passengers, it's important to familiarize yourself with your bike's capabilities by referring to its user manual and/or QuickStart Guide.

Safety Notes

Check Local Regulations

⚠ It may be illegal to carry passengers on a bike in your area even if it has been designed or configured to do so. Check your local regulations before carrying passengers.

Know Your Riding Condition

Both front and rear tires must always remain in contact with the ground when riding with passengers. No passenger is allowed when riding on unimproved or unmaintained trails with a natural surface, even if your bike is designed to handle such terrain.

Follow Installation Procedures

Check to ensure accessories have been correctly installed and securely fastened before riding.

Follow Your Bike's Max Gross Vehicle Weight Limits

⚠ Check your bike's user manual and/or QuickStart Guide for information about maximum gross vehicle weight* and/or cargo weight** limits. Please do not exceed these weight limits.



* Maximum gross vehicle weight is the total weight of the bike, riders (the cyclist and any passengers), accessories, and cargo.

** Cargo weight is the total weight of passengers, accessories, and cargo.

Riding with Passengers

Wear a Helmet

Rider and rear passenger(s) are strongly advised to wear an approved helmet.

Do NOT Leave Children Unattended

Do not allow your children to climb onto the bike nor leave your children unattended on the bike, even if it is on the kickstand. Wriggling children can upset the balance of the bike and a fall may result in serious injuries.

Use Proper Equipment

⚠ The bike must have the following accessories installed in order to safely transport rear passenger(s):

- 1. Seating.** Purpose-built rear seating, chosen according to the passenger's needs
- 2. Handhold.** Something for the passenger to hold on to, other than the bike itself
- 3. Foot support.** Fixed platforms or dedicated foot rests on both sides of the bike
- 4. Foot and leg protection.** Something to prevent feet and legs from getting caught in the spinning wheel
- 5. Double kickstand (optional).** Dual-leg kickstand with a wide stance that keeps a bike standing firmly on the ground, providing extra stability when loading and unloading a young passenger

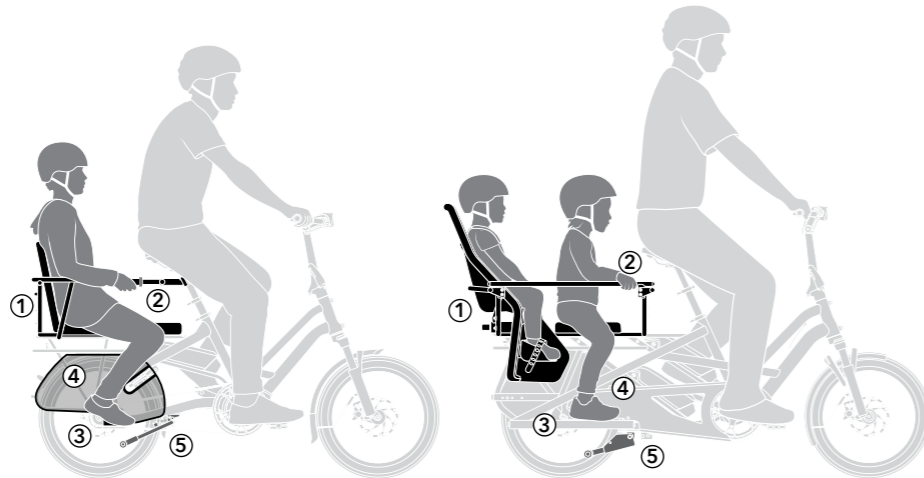

The illustrations above show a mix of suggested gear to safely carry passengers. Your combination of passenger accessories may differ depending on your needs. To learn more about how to safely carry passengers on your bike, visit ternbicycles.com/support.

Use Accessories Properly

If you're carrying young children on your bike, please follow the instructions provided by your child seat manufacturer for compatibility, proper installation, and recommended use to ensure your child's safety and comfort.

Our seating accessories are strictly for sitting. Using them for other purposes such as lifting the bike may cause damage to the frame and/or said accessories.

Our rear handhold accessories are intended for passengers to hold onto. Select rear rack-mounted handholds may be used to briefly lift the bike over small obstacles, but in general please refrain from adding substantial weight on the top of or using the rear passenger handholds to lift the bike, as this will cause undue stress which may damage the bike.

Our foot support accessories are strictly for passenger use when SEATED. Standing on them is unsafe and may permanently damage the frame.



Scan to view available passenger seating accessories