

Before carrying passengers, it's important to familiarize yourself with your bike's capabilities by referring to its user manual and/or QuickStart Guide.

## Safety Notes

### Check Local Regulations

⚠ It may be illegal to carry passengers on a bike in your area even if it has been designed or configured to do so. Check your local regulations before carrying passengers.

### Know Your Riding Condition

Both front and rear tires must always remain in contact with the ground when riding with passengers. No passenger is allowed when riding on unimproved or unmaintained trails with a natural surface, even if your bike is designed to handle such terrain.

### Follow Installation Procedures

Check to ensure accessories have been correctly installed and securely fastened before riding.

### Follow Your Bike's Max Gross Vehicle Weight Limits

⚠ Check your bike's user manual and/or QuickStart Guide for information about maximum gross vehicle weight\* and/or cargo weight\*\* limits. Please do not exceed these weight limits.



\* Maximum gross vehicle weight is the total weight of the bike, riders (the cyclist and any passengers), accessories, and cargo.

\*\* Cargo weight is the total weight of passengers, accessories, and cargo.

## Riding with Passengers

### Wear a Helmet

Rider and rear passenger(s) are strongly advised to wear an approved helmet.

### Do NOT Leave Children Unattended

Do not allow your children to climb onto the bike nor leave your children unattended on the bike, even if it is on the kickstand. Wriggling children can upset the balance of the bike and a fall may result in serious injuries.

### Use Proper Equipment

⚠ The bike must have the following accessories installed in order to safely transport rear passenger(s):

- 1. Seating.** Purpose-built rear seating, chosen according to the passenger's needs
- 2. Handhold.** Something for the passenger to hold on to, other than the bike itself
- 3. Foot support.** Fixed platforms or dedicated foot rests on both sides of the bike
- 4. Foot and leg protection.** Something to prevent feet and legs from getting caught in the spinning wheel
- 5. Double kickstand (optional).** Dual-leg kickstand with a wide stance that keeps a bike standing firmly on the ground, providing extra stability when loading and unloading a young passenger

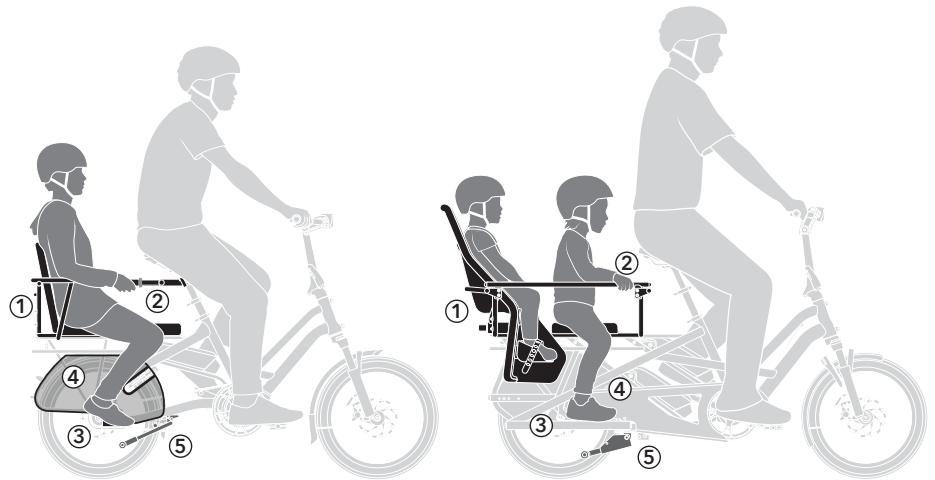

The illustrations above show a mix of suggested gear to safely carry passengers. Your combination of passenger accessories may differ depending on your needs. To learn more about how to safely carry passengers on your bike, visit [ternbicycles.com/support](http://ternbicycles.com/support).

### Use Accessories Properly

If you're carrying young children on your bike, please follow the instructions provided by your child seat manufacturer for compatibility, proper installation, and recommended use to ensure your child's safety and comfort.

Our seating accessories are strictly for sitting. Using them for other purposes such as lifting the bike may cause damage to the frame and/or said accessories.

Our rear handhold accessories are intended for passengers to hold onto. Select rear rack-mounted handholds may be used to briefly lift the bike over small obstacles, but in general please refrain from adding substantial weight on the top of or using the rear passenger handholds to lift the bike, as this will cause undue stress which may damage the bike.

Our foot support accessories are strictly for passenger use when SEATED. Standing on them is unsafe and may permanently damage the frame.



Scan to view available passenger seating accessories

# Stow Decks

Manual Version 01

Make sure you have the latest support resources!

Visit [ternbicycles.com/support](http://ternbicycles.com/support) for:



MANUALS



ARTICLES



VIDEOS



& MORE



## Weight Limits

- 35 kg (77 lb) max load per deck on paved roads.
- 17 kg (37 lb) max load per deck on graded and maintained gravel roads.\*

\* Riding off-road poses unique challenges. Reduce the max load by approximately 50% if riding on unpaved roads to ensure safety. Refer to the 'Intended Use' section in your bike's QuickStart Guide to learn more about suitable riding terrains.

## Safety

- ▲ Never exceed the Maximum Gross Vehicle Weight (MGVW) of your bike. The MGVW is the total weight of the bike, riders (the cyclist and any passengers), accessories, and cargo.
- ▲ Load Decks so that cargo is placed towards the middle rather than outer edges of the Decks, and weight is distributed as evenly as possible across entire surface of the Decks.
- ▲ Make sure load weight is distributed evenly on both sides of the bike.
- ▲ Secure all cargo before riding. Take care that all Straps are tied down and any loose items are secured.
- ▲ Check to ensure all accessories have been correctly installed and securely fastened before riding.
- ▲ Your bike may behave differently with cargo and passengers.

## What's Included

### 1. Quick Lock Pin Sets

- Quick Lock Pin x 2
- M5 x 12 Dome Head Bolt x 4

### 2. Rubber Bumper Sets

- M5 x 30 Dome head Bolt x 4
- M5 Washer x 8
- M5 Nylon Nut x 4
- Rubber Bumper x 4

### 3. Stow Deck & Attachment Sets

- Stow Deck x 2
- M8 x 35 Bolt x 4
- M8 Washer x 8
- M8 Nylon Nut x 4

### 4. Set Screws

- M6 x 16 Set Screw x 2

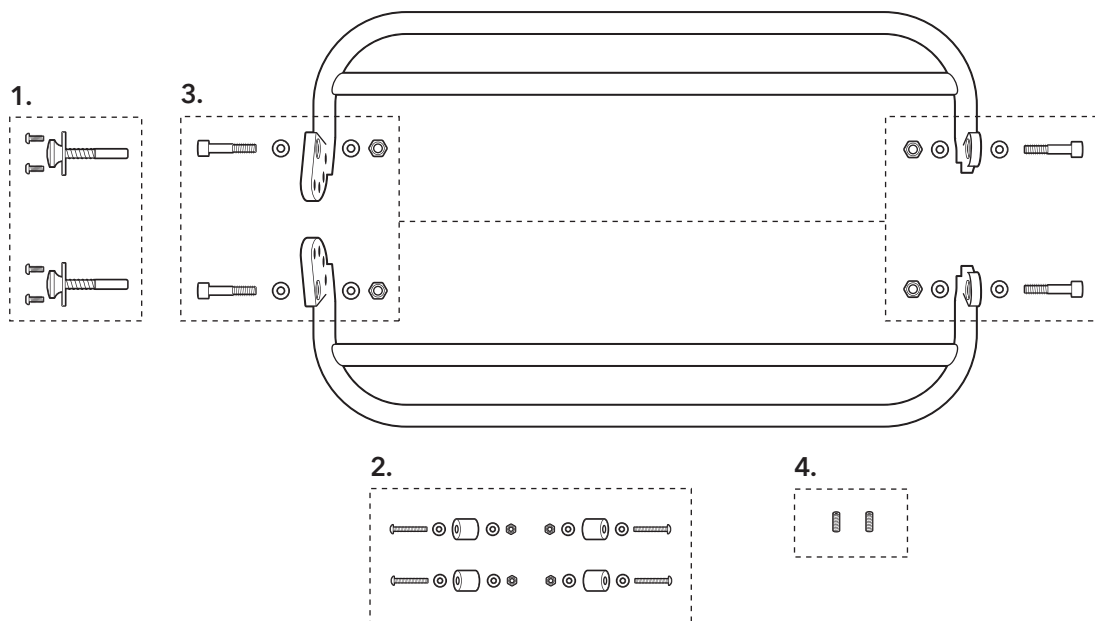

# Stow Decks

## How to Install on Orox™

Installation is divided into the below 4 sections. Please install all components in this sequence and follow the same steps as shown for each Deck.

1. Install Quick Lock Pin
2. Install Rubber Bumper
3. Install Stow Deck
4. Install Set Screw

## Tools Required (Not Included)

- 3 mm Allen Wrench
- 6 mm Allen Wrench
- 8 mm Open Wrench
- 13 mm Open Wrench

**▲ Add anti-seize lubricant to the tip of the Bolts before securing the Nuts. If anti-seize lubricant is not available, apply any standard lubricant to reduce friction and prevent thread galling.**

### 1. Install Quick Lock Pin

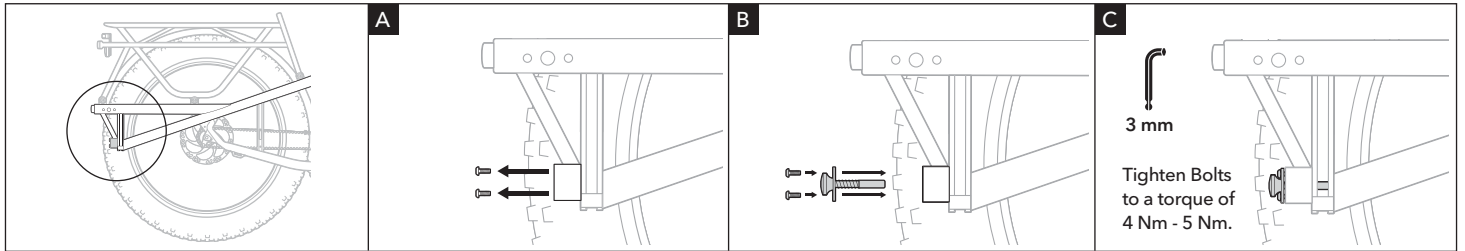

### 2. Install Rubber Bumper

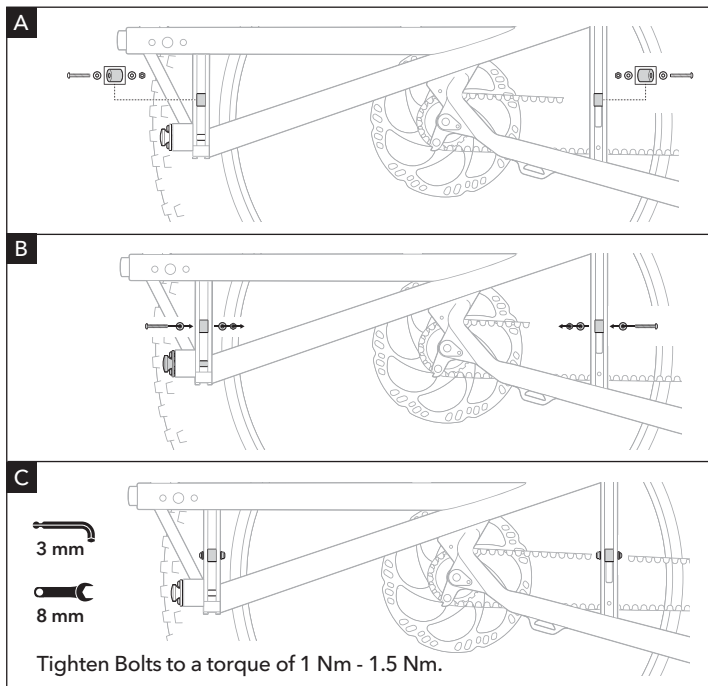

### 3. Install Stow Deck

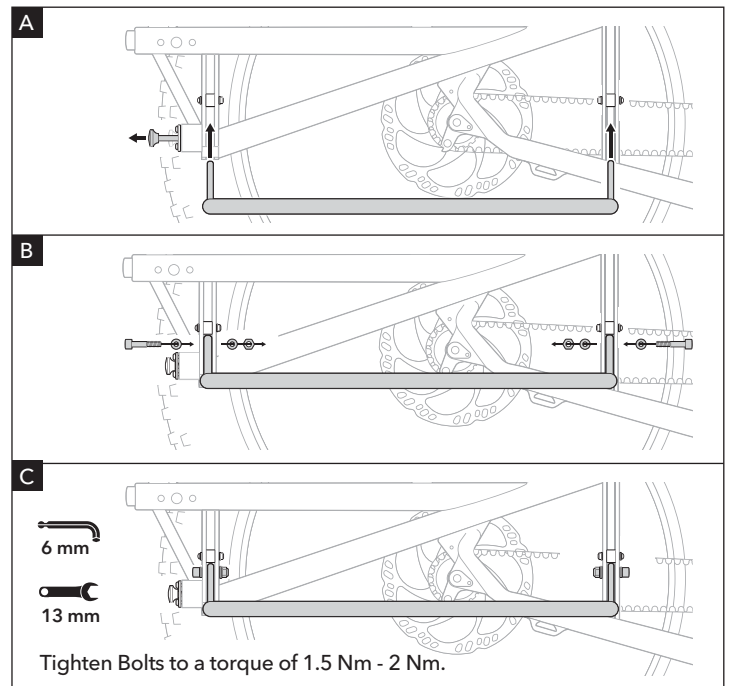

### 4. Install Set Screw

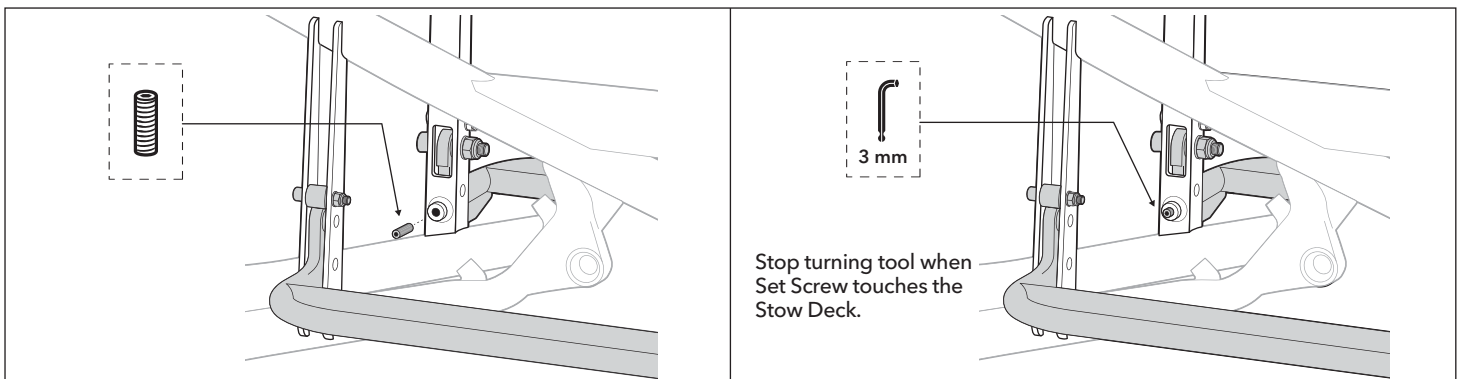

# Stow Decks

## How to Use Stow Decks

The Stow Decks can be deployed in 5 different angles to meet cargo or passenger needs.

▲ For your safety, make sure Quick Lock Pin is securely in place to lock Stow Decks before riding.

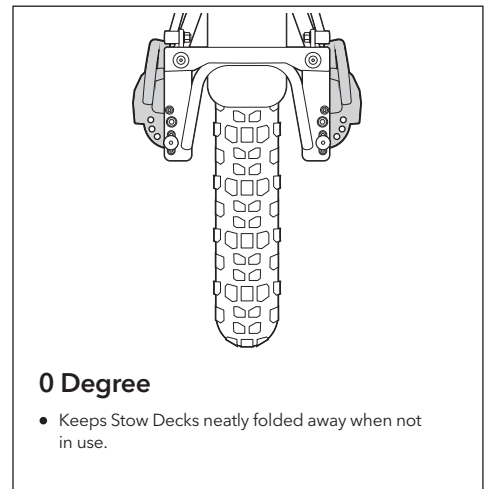
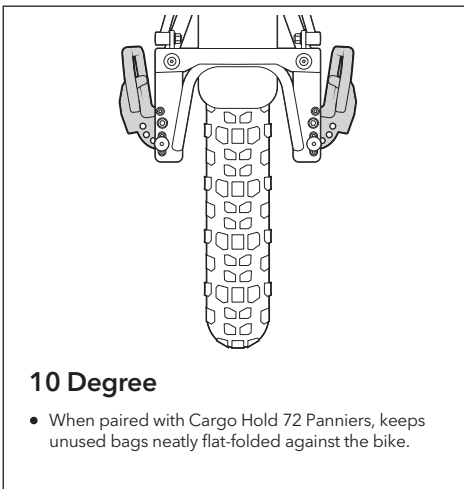
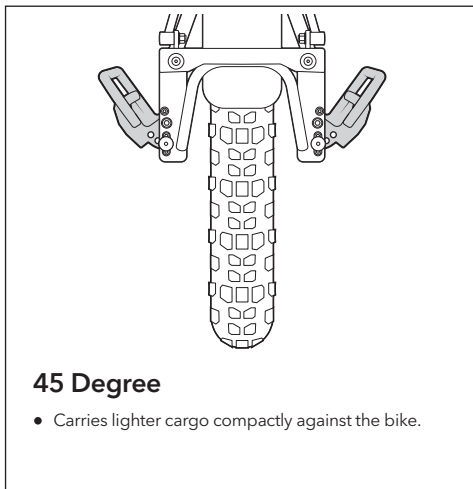
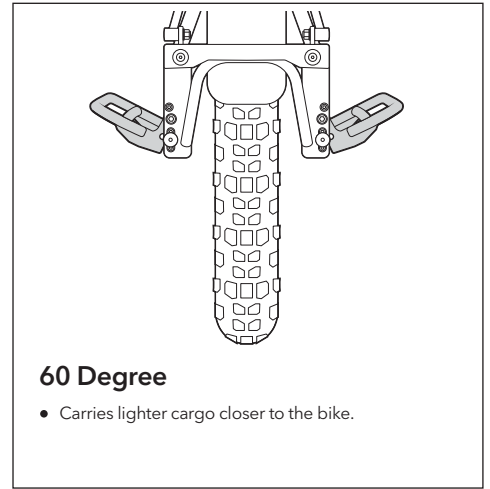
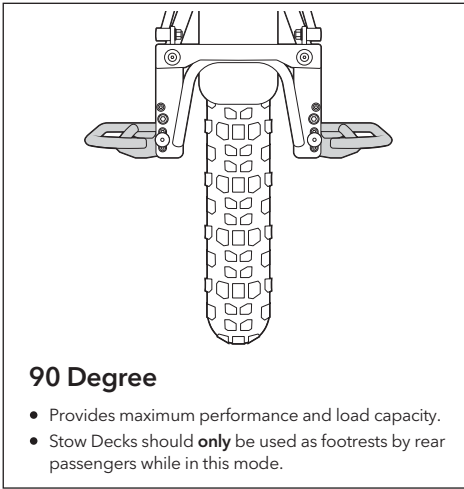
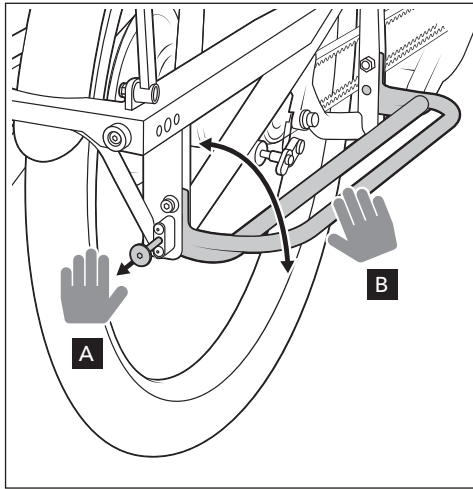

## Additional Accessories

Give your bike massive cargo capacity and the extra stability it needs when you load and unload oversized cargo or young passengers.

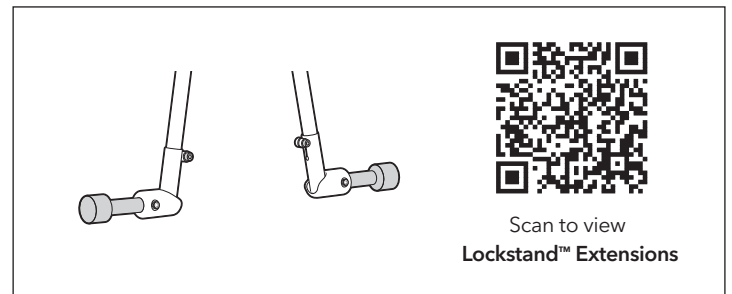
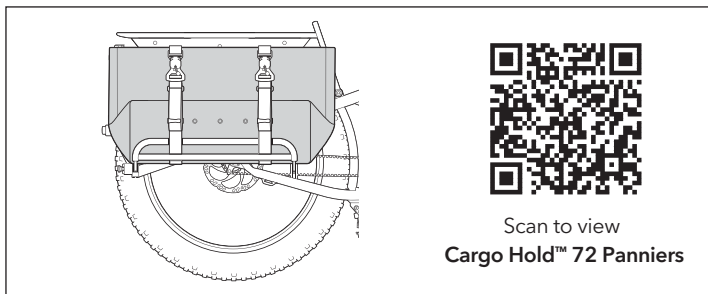

LIMITED PRODUCT WARRANTY INFORMATION: This Product comes with a ONE (1) YEAR Limited Warranty from the date of retail purchase by the original end-user. If a material or workmanship defect arises and a valid claim is received within the Warranty Period, this Product will be replaced. Mobility Holdings cannot be held liable for damages to personal property due to misuse or improper care and maintenance. This Product Warranty does not, under any circumstance, cover the replacement or cost of any third party product used with or connected to the Product.

Tern, the Tern Werd (logotype), the Tern Berd (device), Orox, Lockstand, Stow Decks, and Cargo Hold used alone or in combination are trade names, trade devices or registered trademarks of Mobility Holdings, Ltd.

© 2024. Tern is a trademark of Mobility Holdings, Ltd. All Rights Reserved.

@ternbicycles

ternbicycles.com

