

Manual Version 01

Make sure you have all the latest information needed to use and enjoy this product!

Visit ternbicycles.com/support for updated:



What's Included

1. Cache Box
2. Cable Tie
3. M5 x 12 mm Screws (3)
4. M5 Washers (3)

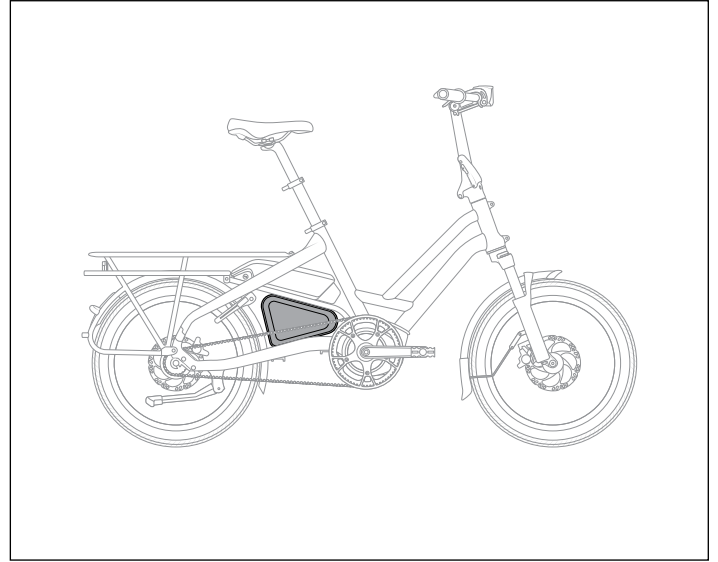
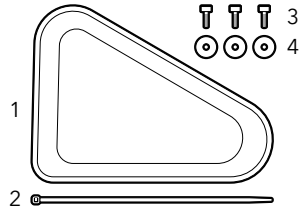

Installation

Tools Required (Not Included)

- 4 mm Allen Wrench
- Scissors

Dimensions

- Volume: 1.9 L (116 cu in) carrying capacity
- Weight: 2 kg (4.4 lb) maximum load

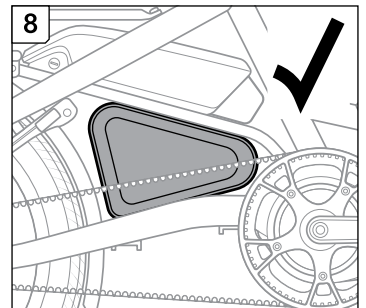
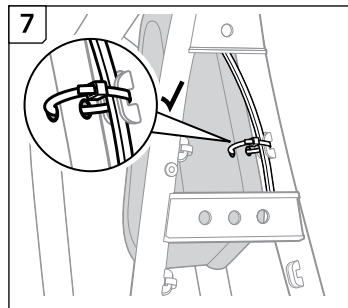
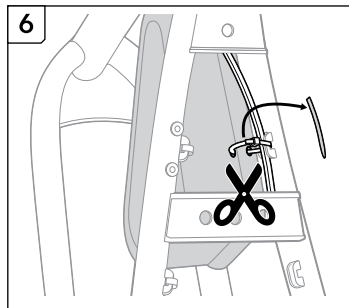
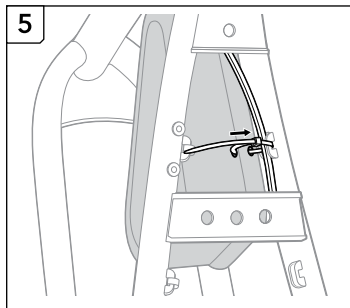
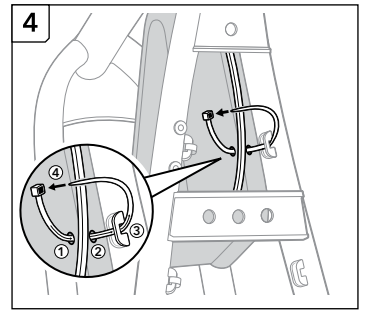
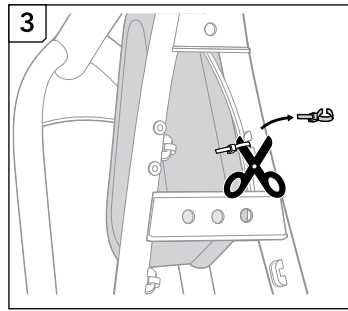
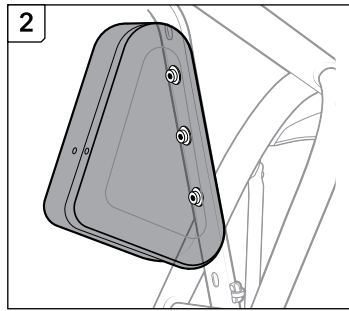
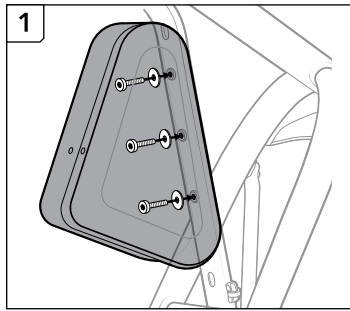

LIMITED PRODUCT WARRANTY INFORMATION: This Product comes with a ONE (1) YEAR Limited Warranty from the date of retail purchase by the original end-user. If a material or workmanship defect arises and a valid claim is received within the Warranty Period, this Product will be replaced. Mobility Holdings cannot be held liable for damages to personal property due to misuse or improper care and maintenance. This Product Warranty does not, under any circumstance, cover the replacement or cost of any third party product used with or connected to the Product.

Tern, the Tern Werd (logotype), the Tern Berd (device), and Cache Box used alone or in combination are trade names, trade devices, or registered trademarks of Mobility Holdings, Ltd.

© 2024. Tern is a trademark of Mobility Holdings, Ltd. All Rights Reserved.



@ternbicycles

ternbicycles.com