

Manual Version 02

Make sure you have all the latest information needed to use and enjoy this product!

Visit ternbicycles.com/support for updated:



MANUALS



COMPATIBILITY



ARTICLES



VIDEOS



& MORE



Attention

- Backrest is intended for use by kids approx. 22 - 36 kg (49 - 80 lb), capable of sitting unaided.
- A restraint system for your child may be required by local regulations. Scan the QR code at the end of this manual to view available passenger accessories, including restraint options.

What's Included

- Clubhouse Backrest
- Backrest Hinge
- Fastening Strap, 50 x 185 mm

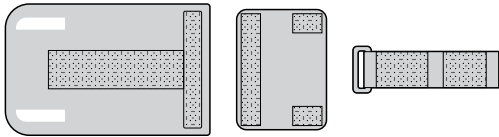

General Care & Maintenance

To clean, wipe using dampened cloth with mild soap.

- ⚠ Do not use bleach or other harsh chemicals
- ⚠ Do not machine wash or machine dry
- ⚠ Keep Backrest away from sharp objects
- ⚠ Store Backrest away from direct sunlight when not in use

Installation

⚠ Clubhouse Seat Pad™ and a compatible Clubhouse® or Clubhouse Mini™ are required for Backrest installation.

1. Position Fastening Strap on center of Rear Bar.

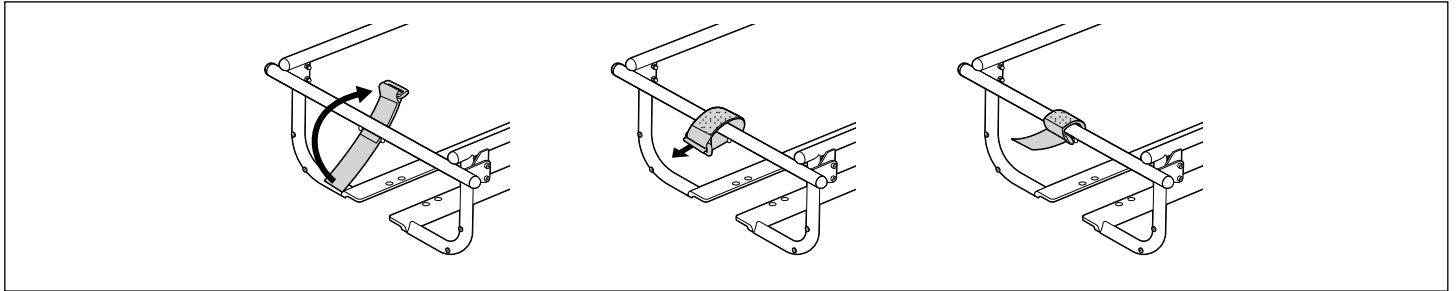

2. Join Clubhouse Backrest and Seat Pad with Backrest Hinge.

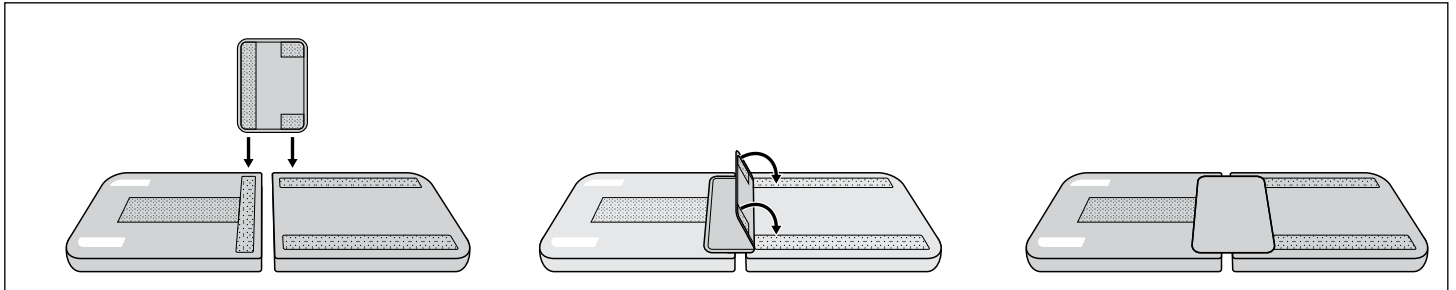

3. Align self-fastening strips and press firmly.

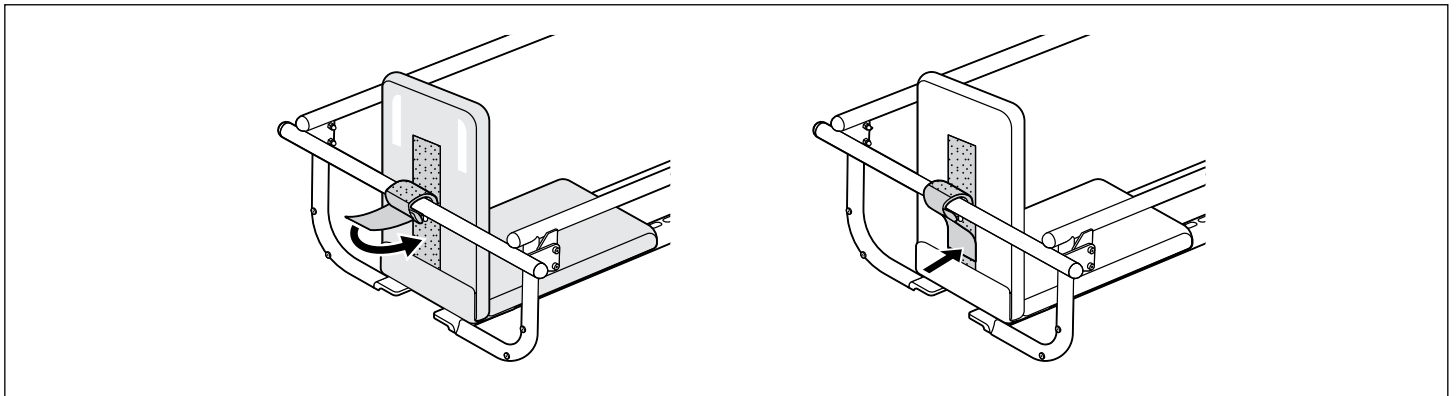

Clubhouse Backrest™

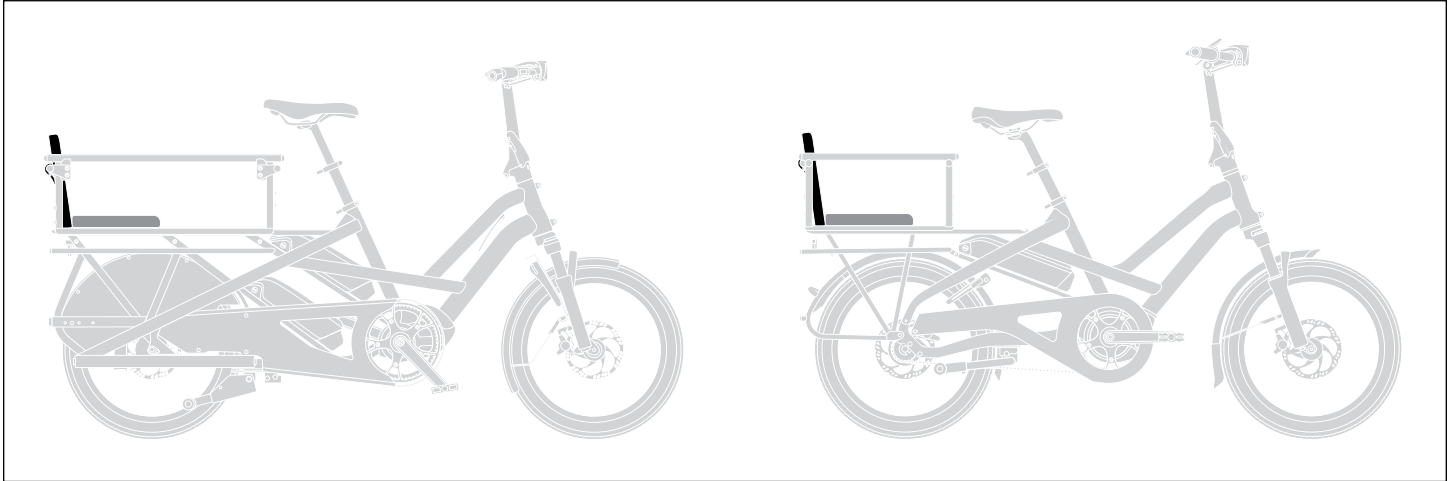

LIMITED PRODUCT WARRANTY INFORMATION: This Product comes with a ONE (1) YEAR Limited Warranty from the date of retail purchase by the original end-user. If a material or workmanship defect arises and a valid claim is received within the Warranty Period, this Product will be replaced. This warranty does not cover normal wear and tear, routine maintenance, or damages caused by misuse or improper care. For the full terms of this warranty, see ternbicycles.com/warranty.

© 2026. Mobility Holdings, Ltd. All Rights Reserved. TERN, tern (stylized), the Berd image, and Clubhouse are each registered trademarks of Mobility Holdings, Ltd. in at least one of the United States, EU, or other jurisdictions. In other jurisdictions, Mobility Holdings, Ltd. claims rights to these marks to the fullest extent permitted by applicable law.

   @ternbicycles

ternbicycles.com

Carrying Rear Passengers

Before carrying passengers, it's important to familiarize yourself with your bike's capabilities by referring to its User Manual or QuickStart Guide.

WARNINGS

- Your bike may behave differently with passengers onboard, particularly in terms of balance, steering, and braking. Practice handling the bike in a safe area before riding with passengers on public roads.
- Do not leave children unattended on the bike, even if it is on the kickstand. Wriggling children can upset the balance of the bike and a fall may result in serious injuries.
- If your bike has been parked outdoors, check all passenger contact surfaces for heat to prevent burns.

Safety Notes

⚠ Follow the Law

Check your local regulations before carrying passengers. Some jurisdictions don't allow passengers, others require special accessories, and some limit the number or age of passengers.

⚠ Stay Within the Weight Limits

Always follow the weight limits listed in your bike and accessory manuals, including the bike's maximum gross vehicle weight (MGVW). **The combined weight of the bike (with battery), accessories, rider, passengers, and cargo must not exceed the MGVW for safe riding.**

⚠ Know Your Riding Condition

Keep both tires on the ground when riding with passengers. Do not carry passengers on unimproved or unmaintained natural-surface trails.

⚠ Keep Your Bike Steady for Passengers

Before loading or unloading passengers, make sure the bike is stable and parked on a firm, level surface. If passengers mount or dismount on their own, hold the bike steady to prevent tipping.

⚠ Ensure Your Bike Setup is Safe & Secure

- Before each trip, check that accessories have been correctly installed and secured, and ensure there are no loose items on the bike or on your passenger(s) that may get caught in moving bike parts. Keep sharp objects away from children, and suitably cover any coil springs (e.g. under the saddle) to prevent trapping of fingers.
- Regularly check your bike setup for worn or damaged parts. Always use genuine replacements and replace any damaged parts immediately, either by a qualified mechanic or following the manufacturer's instructions.

⚠ Use Helmet & Proper Clothing

Always follow local helmet laws. For safety, riders and passengers are strongly advised to wear an approved helmet. In cold or wet weather, dress young passengers warmly and protect them from the elements.

Use a Suitable Passenger Setup

⚠ Your bike must have proper accessories for the following purposes to safely carry rear passenger(s):

1. **Seating***. Purpose-built rear seating, chosen according to the passenger's needs
2. **Handhold**. Something for the passenger to hold on to, other than the bike itself
3. **Foot support**. Fixed platforms or dedicated foot rests on both sides of the bike
4. **Foot and leg protection**. Something to prevent feet and legs from getting caught in the spinning wheel
5. **Double kickstand**. Dual-leg stand with a wide stance for extra stability when loading or unloading passengers

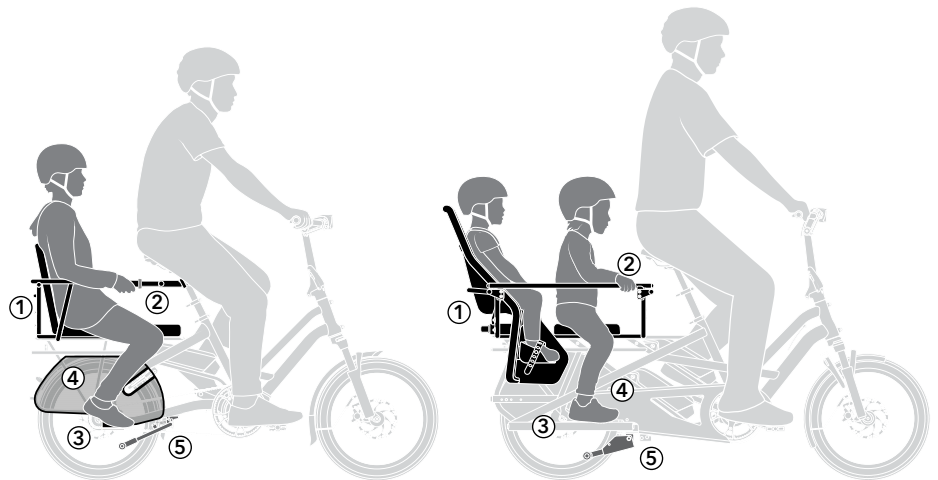

* Only use seating suitable for your passenger's age and size, and follow the seat manufacturer's instructions for compatibility, installation, use, and maintenance. Child passengers should be able to sit unaided for the duration of the ride. Always secure them with the provided restraint system, and regularly check that their height and weight remain within the manufacturer's limits.

Note: The illustrations show examples of gear for safely carrying rear passengers. Your setup may vary. Tern's seating, handhold, and foot support accessories are not intended for lifting the bike or bearing heavy loads, unless specified, as this may damage the bike or accessories.

For more information on accessories or recommended passenger setups, visit ternbicycles.com



Scan to view available passenger accessories